

EXTRACTOR AXIAL FA10-25 900 m³/h

Ventilador axial mural de acero galvanizado protegido con pintura poliéster anticorrosiva motor monofásico IP40 clase B con cable de conexión incorporado.

Sentido del aire: Motor-Hélice

Características

Caudal	: 900 [m ³ /h]
Potencia	: 40 [watts]
Voltaje	: 220/50 [volt/Hz]
Rpm	: 1400
NPS	: 50 [dB (A)]
Peso	: 3,5 [kg]



Dimensiones (mm)

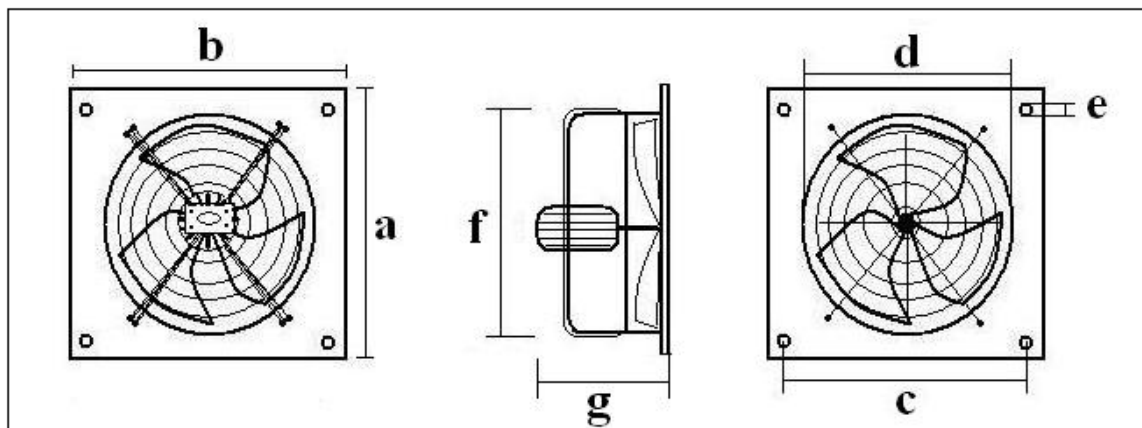

a	b	c	d	e	f	g
350	350	323	300	7	400	16,5